

ROOM EXTENSION RACK SENSING VALVE TROUBLE SHOOTING / REPLACEMENT / ADJUSTMENT

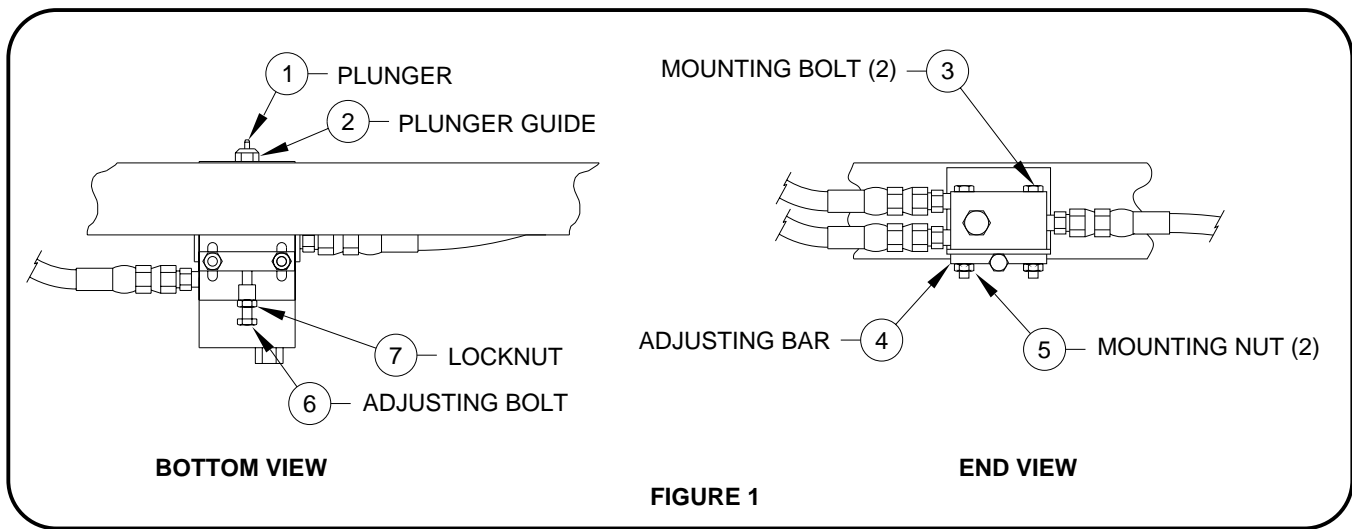

TROUBLE SHOOTING

There are no field repairs that can be done to the rack sensing valve. When there is a malfunction the complete valve is to be replaced.

There are three basic problems that may be caused by the rack sensing valve.

1. There is an external oil leak : Replace the rack sensing valve if it is leaking through the plunger guide (2, FIGURE 1). Check that the hose fittings are tight.
2. Both ends of the room are not moving at an equal distance from the vehicle : The valve may need to be adjusted or the plunger may be bent. If the plunger is bent, replace the valve.
3. The room has a jerky motion when extending or retracting : The plunger (1, FIGURE 1) is sticking. Replace the valve.

REPLACEMENT

When replacing a rack sensing valve, the valve release "T" handles for both valves on the room extension manifold must be opened (counterclockwise) 5 to 6 turns to relieve the pressure on the system (FIGURE 2). Only the two solenoid valves for that room extension need to be opened.

Loosen the rack sensing valve mounting bolts (3 & 4, FIGURE 1). Remove the adjusting bolt and locknut (6 & 7, FIGURE 1). Remove the three hydraulic lines from the valve. Remove the mounting bolts and valve adjusting bar (5, FIGURE 1). Replace the valve but do not tighten the mounting bolts. Replace the hydraulic lines and the adjusting bolt and locknut. Adjust the valve so approximate 1/4 inch of the plunger (1, FIGURE 1) is showing. Close the valve release "T" handles. Run the room in and out and make the final adjustment of the rack sensing valve. (See ADJUSTMENT PROCEDURE on back) Tighten the mounting bolts and check for leaks and the fluid level.

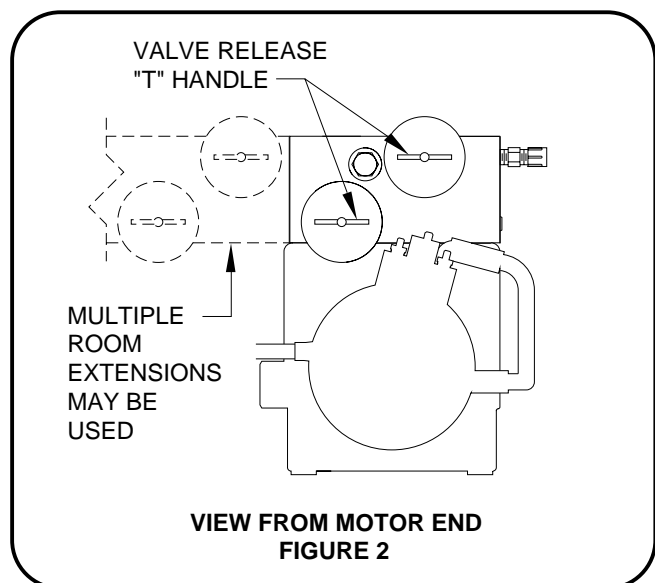

ROOM EXTENSION RACK SENSING VALVE TROUBLE SHOOTING / REPLACEMENT / ADJUSTMENT

ADJUSTMENT

Extend the room 6 inches then retract. Do this several times to remove air from the system. Extend the room approximately 6 inches. Both ends of the room should move at an equal distance from the vehicle. **If the difference is approximately 1/2 inch or less do not adjust the valve.** The movement of the room can be adjusted by moving the rack sensing valve in or out using the valve adjusting bolt. (6, FIGURE 1) Loosen the rack sensing valve mounting bolts (3 & 4, FIGURE 1) and the adjusting locknut. (7, FIGURE 1) Do not tighten these until the adjustment is complete. Refer to FIGURE 3 or 4 depending on which side of the room is leading, for the proper adjustment of the valve.

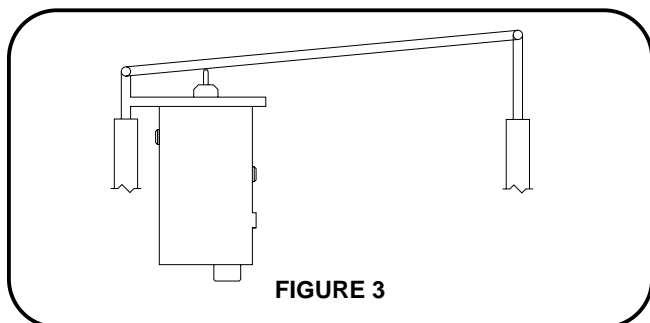

FIGURE 3

If the valve side of the room is moving at a closer distance to the vehicle (FIGURE 3) turn the adjusting bolt (6, FIGURE 1) clockwise 1 turn. **NOTE** : If the difference is minor, less than 1 turn may be appropriate. Extend the room an additional 12 inches. Retract the room that 12 inches and check the measurement. Repeat this procedure as necessary. The difference in the measurement should be 1/2 an inch or less. Tighten the mounting bolts and adjusting locknut when the adjustment is complete.

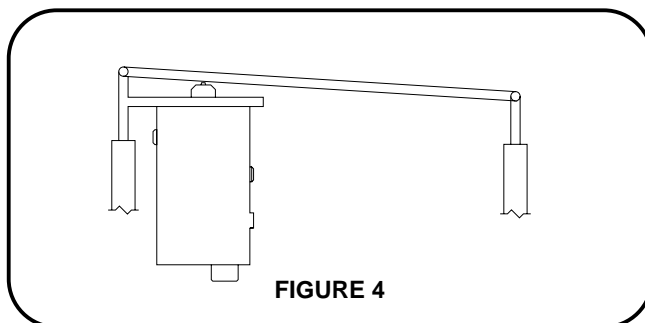

FIGURE 4

If the valve side of the room is moving at a greater distance from the vehicle (FIGURE 4) turn the adjusting bolt counter clockwise 1 turn. **NOTE** : If the difference is minor, less than 1 turn may be appropriate. Extend the room an additional 12 inches. Retract the room that 12 inches and check the measurement. Repeat this procedure as necessary. The difference in the measurement should be 1/2 an inch or less. Tighten the mounting bolts and adjusting locknut when the adjustment is complete.

REMEMBER : If the room is racking from side to side while moving, adjusting the rack sensing valve will not fix the problem.