

HWH® Straight-Acting, Power-Extend/Power-Retract Precision Leveling Jack

AP44699 24,000 lb. Jack with a 16" Stroke

For vehicles requiring Precision Leveling within .05 degrees

**Adjustable Metering Valve
to accurately level vehicle.
(Allows tailoring to
different configurations)**



**Mechanical Override
(for emergency operation)**

**Control Valves are directly
mounted to jack.
(No hose connection)**

Includes the following features...

- Hydraulic power-extend/power-retract straight-acting jack
- 24,000 pound capacity jack in various stroke lengths
- Corrosion-protected rods resist rust for long life in harsh environments
- Large swiveling foot pads conform to ground for greater stability
- Easy to install with weld-on brackets and simple hydraulic and electric connections



(On I-80, Exit 267 South) | 2096 Moscow Road | Moscow, Iowa 52760
Phone: (800)321-3494 or (563)724-3396 | Fax: (563)724-3408 | Web: www.HWH.com

Made in the USA

STRONG, RELIABLE, HYDRAULIC POWER

Specifications & Features

HWH®: Straight-Acting, Power-Extend/Power-Retract Precision Level Jack AP44699 - 24,000 lb. Jack with a 16" Stroke

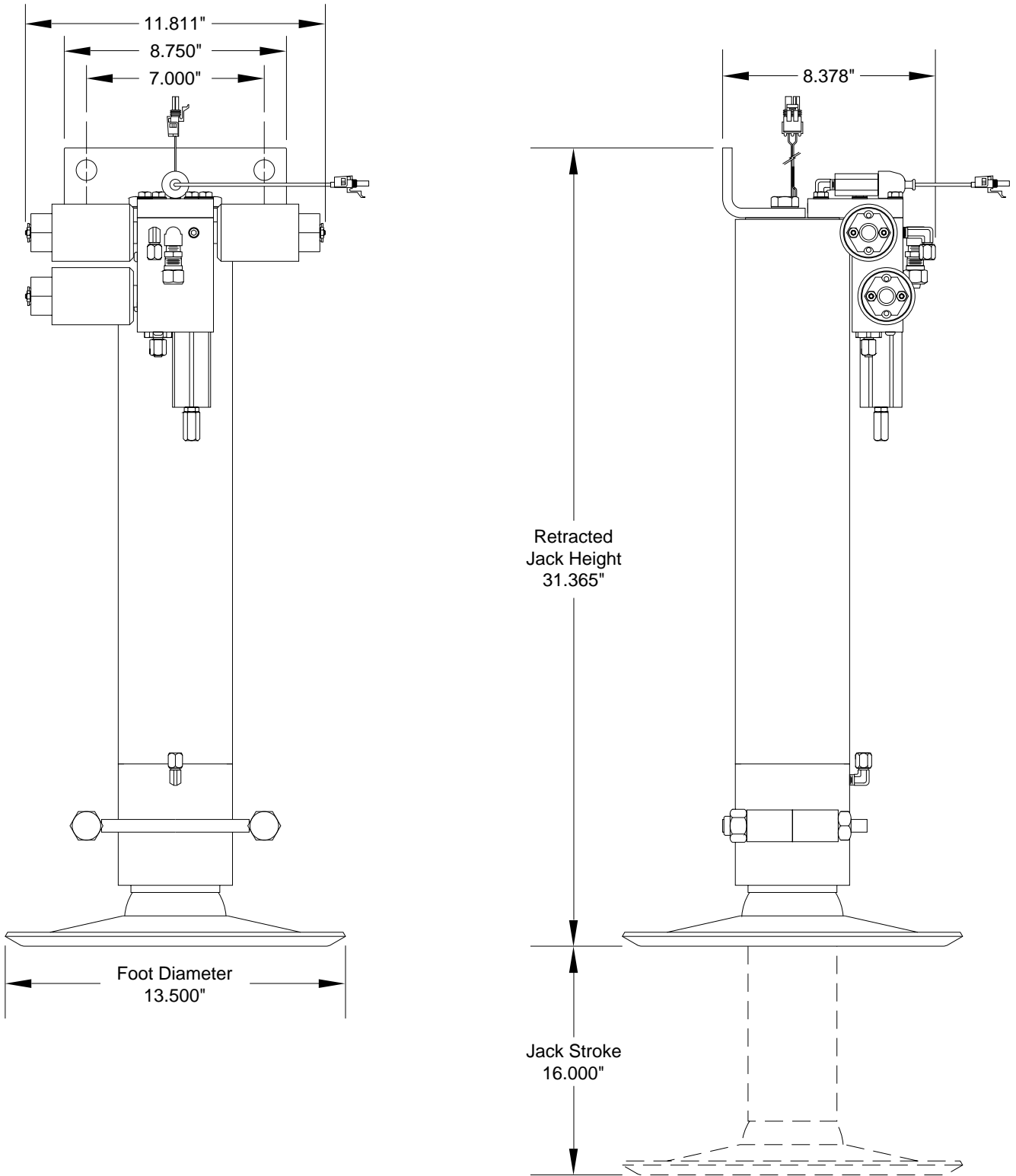

Specifications...

WEIGHTS (lbs.)	
Each Jack Assembly	XX
LOAD PER JACK (lbs.)	24,000